

Slide each completed railing section down onto the exposed fasteners as shown on page 3 (Step 3a). It is important your railing sections are vertically and horizontally level before fastening the top bracket (Step 5b) to your newel post. Repeat step for all sections including the stair rails.

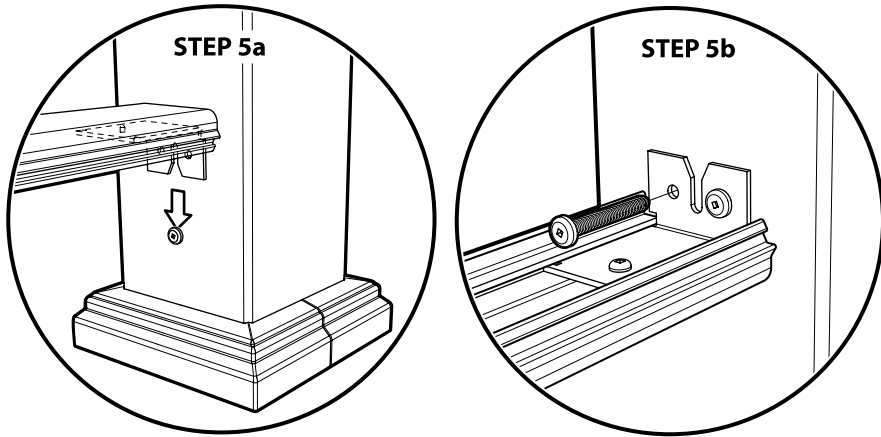

Upon completing the installation of your railing sections cut your top and bottom covers to their matching lengths. Snap the covers on by hand and use a rubber mallet to ensure a good seal. Glue the inside lips of caps with standard PVC glue or silicone and place on newel posts.

NOTE: For stair railing installation the mounting 'L' brackets will have to be bent manually to the appropriate angle for your rail slope.

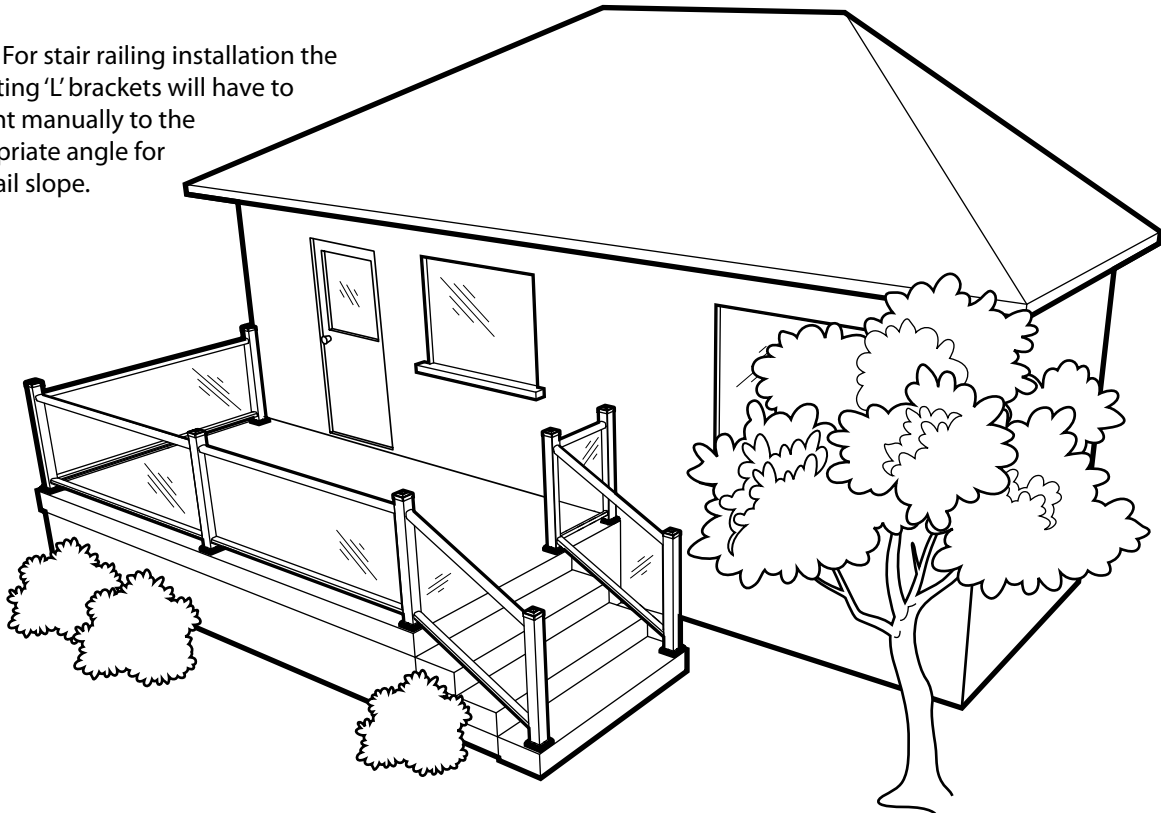

# Alpa Vinyl-Clad Structural Railing INSTALLATION GUIDE



SUPPLIED BY:

**ALPA**  
OUTDOOR PRODUCTS

**Alpa Outdoor Products Inc.**  
101 Glidden Road  
Brampton Ontario, L6T 3W6  
Tel: (905) 796-6631  
Fax: (905) 796-8790

## Thank you for choosing Alpa Outdoor Products Inc. Structural Railing Product.

Please read this Installation Manual completely before assembling your new structural railing.  
Retain this manual and your dated sales receipt for future reference or warranty claims.

### Installation/Assembly Information

As with any construction project, use caution and safety when assembling your new railing. Alpa Outdoor Products cannot be responsible for any damages or injuries resulting from the incorrect use of any tools, equipment or the mishandling of any of the railing components.

- Use proper lifting when handling the packages.
- Take care when handling the individual components and wear gloves to avoid cuts or scrapes.
- Follow proper operating procedures for any tools, ladders, etc. used when assembling your rail.
- Always protect your eyes. Wear safety glasses when assembling the railing and when using power tools.
- Do not assemble the railing if parts are missing. An assembled railing that has parts missing or the wrong parts installed may cause serious damage.
- The railing must be anchored properly to either a wood substructure or a concrete pad. See the following pages for recommended wood and concrete fasteners. **Lags or concrete anchors are not included.**
- Contractor or Owner to supply fasteners as required to install 4" x 4" newel posts and railing sections.

**This is a maintenance free product made of weatherable vinyl and as such does not need to be painted. Painting of the product will VOID the WARRANTY. If a paintable railing product is needed please contact Alpa Outdoor Products Inc. or your supplier.**

### Tools Requires for Assembly

- Power drill with a #2 type "A" bit(4" in length)
- 3/8" x 4" concrete bit for 3/8" x 3 3/4" Simpson Wedge-All (Concrete mounted application)
- Measuring tape – minimum 16' (5m) recommended
- Safety glasses and gloves
- 3' level and carpenters square
- Rubber mallet
- Chopsaw (10" blade length with 60 teeth)

Railing and newel posts must not be installed in manner contrary to local building codes or the instructions that have been provided. The Alpa Structural Railing system has been tested in Canadian/American approved lab with a maximum span of 8' from the centers of the newel posts and meet or exceed the following standard code bodies:

#### Canadian

#### OBC – 2006 Ontario Building Code

#### Section 9.8.8.2 (1) and Table 9.8.8.2

It complies to the loading requirement of OBC 2006 part 9 division B for Guards more than 1.8 meters above ground. The installer must understand that failure to follow the installation instructions set forth in this manual may result in deficiencies in the final assembly and will VOID the warranty.

### ATTENTION

**Before you assemble your railing:**

**Please take a complete inventory of all parts using the parts list and part identification guide provided. Do not attempt to assemble the railing if parts are missing or damaged.**

**For assistance or replacement parts call your supplier.**

## RECOMMENDED INSTALLATION FOR NEWEL POST ON A WOODEN SUBSTRUCTURE

1. Locate center point for each newel post.
2. Install block below deckboards and be sure to fasten blocking to joists. (See illustration)
3. Place steel post reinforcement over center point and mark anchor locations.
4. Drill 1/8" diameter pilot holes at least 60 to 70% of lags shank.
5. Place steel reinforcement over pilot holes and screw in lags.

### Recommended Wood Lag Screws

A set of four hex head 3/8" x 6.0" steel, zinc plated lag screws with washers.

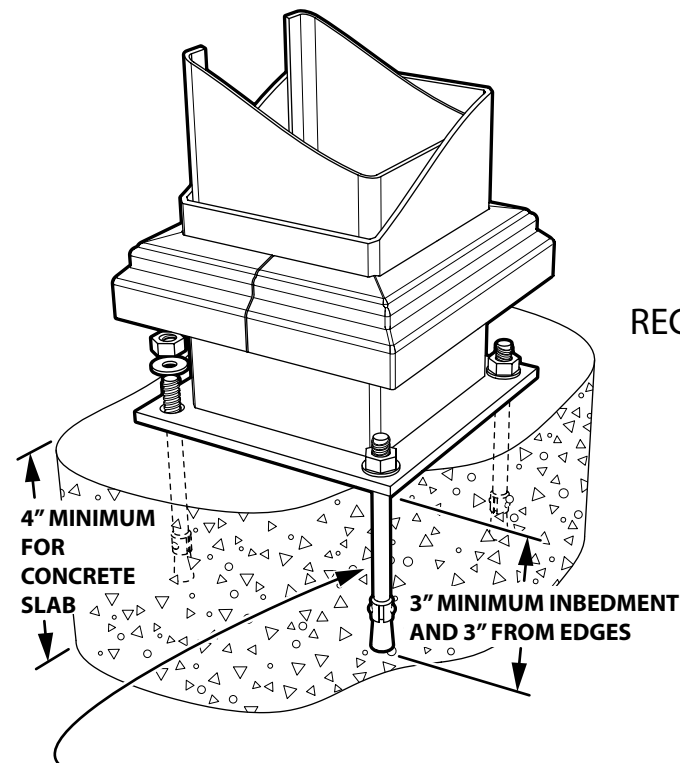

### Recommended Concrete Fasteners

A set of four Simpson Wedge-All fasteners measuring 3/8" x 3-3/4" with washers.

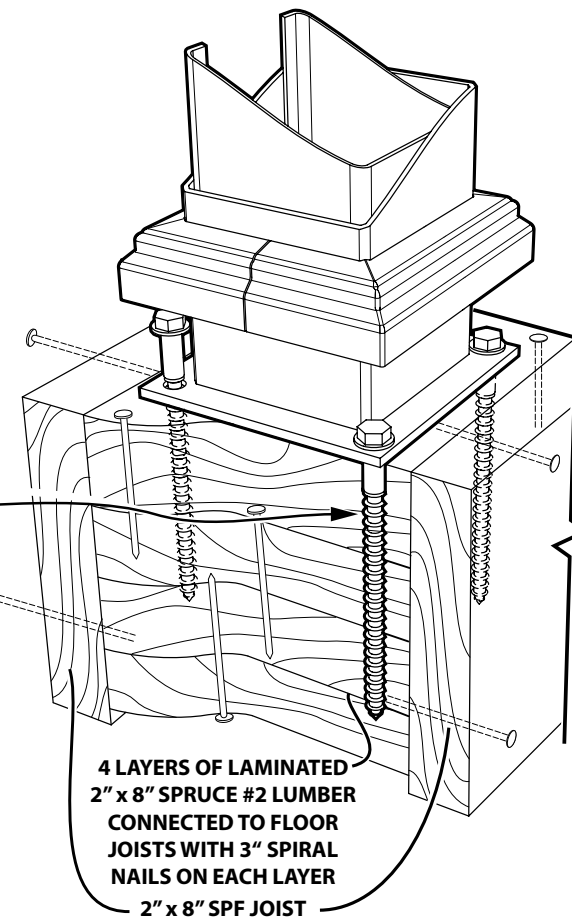

## RECOMMENDED INSTALLATION FOR NEWEL POST ON A CONCRETE SUBSTRUCTURE

1. Locate center point for each newel post.
2. Place steel post reinforcement over center point and mark anchor locations.
3. Drill 3/8" diameter holes to allow a minimum embedment of 3", clean holes of all concrete dust and debris.
4. Tap in concrete fasteners, place the steel post reinforcement over the exposed threaded portions of fasteners. Install washers and nuts then tighten to the recommended 30 ft/lbs of torque.

## INSTALLATION STEPS

### 1. POST REINFORCEMENT INSTALLATION:

- Layout and measure post reinforcements according to the figure on page 4. Maximum of 8' from centre to centre.
- Install post reinforcements according to appropriate method found on page 5.
- Slip on vinyl post cover over post reinforcement

### 2. MEASURE & TRIM RAILS:

- Measure distance (top and bottom) between posts as seen on page 4.
- Cut both rail retainers, top (hand) and bottom rails.
- If needed, assemble balusters with top & bottom retainers using #10, 1-1/2" Pan Head, Type A screws.

### 3. INSTALL BOTTOM POST SCREWS:

- Using a #10, 3/4" self-drilling Tek screw install bottom post screw. Refer to page 3 for method and measurements. (Repeat 2 times)
- Snap on post skirt

### 4. INSTALL 'L' BRACKETS:

Using a #6, 3/8" self-drilling screw secure into place the 'L' bracket flush with the end of the rail retainer ends. (Repeat 4 times)

### 5. INSTALL RAILING:

- Position bottom rail 'L' brackets onto bottom post screws installed in step 3.
- Secure railing into place using #10, 3/4" self-drilling Tek screw. (Repeat 4 times)

### 6. SNAP INTO PLACE TOP (HAND) & BOTTOM RAILINGS

### 7. PUSH ON POST CAP WITH GLUE (Standard PVC Glue)

## BASIC MEASUREMENTS FOR 8' RAILING

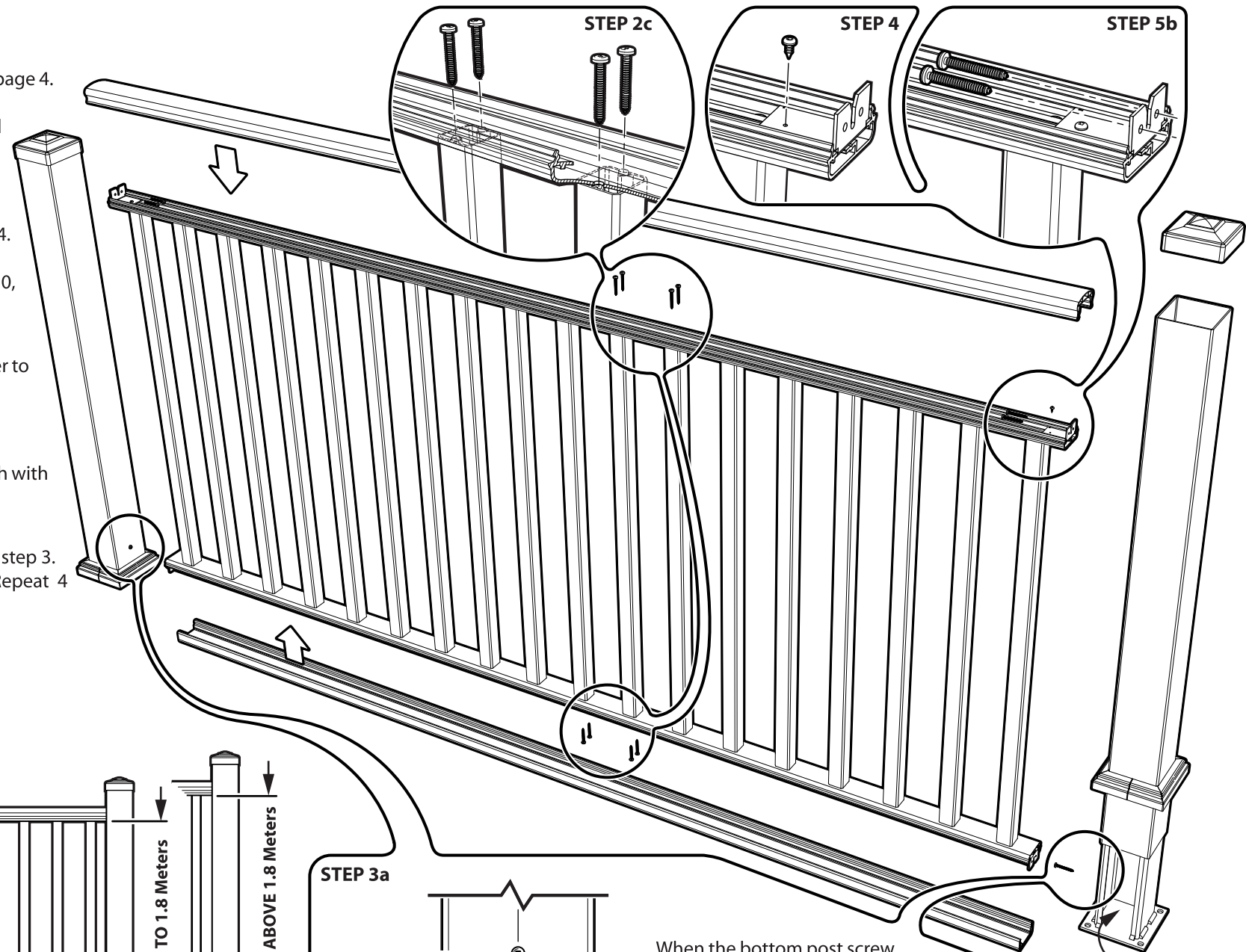
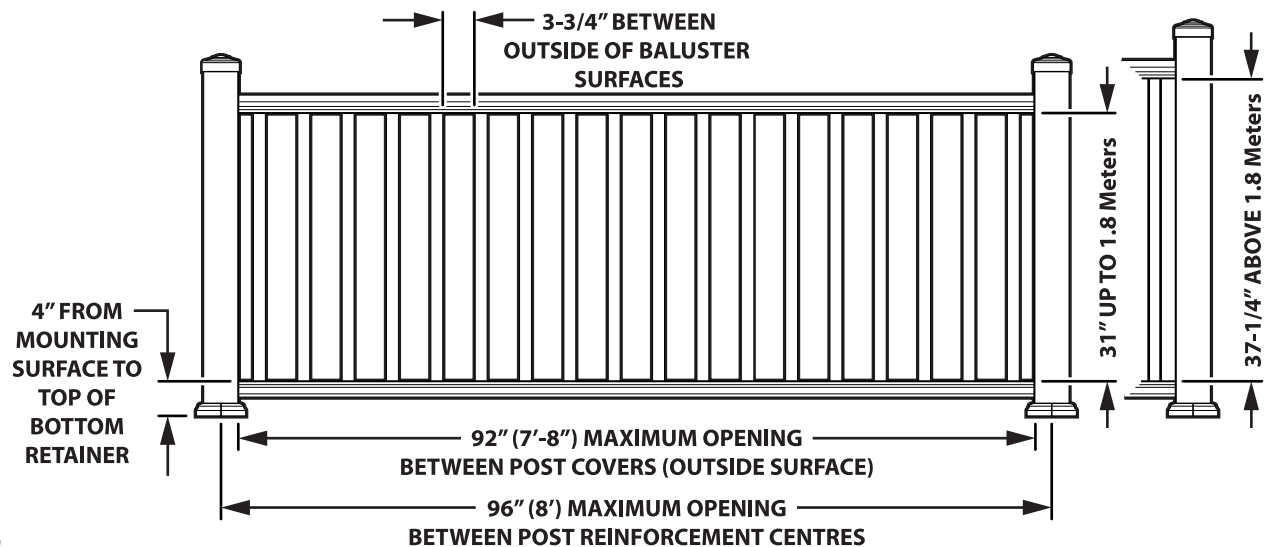

### STEP 3a

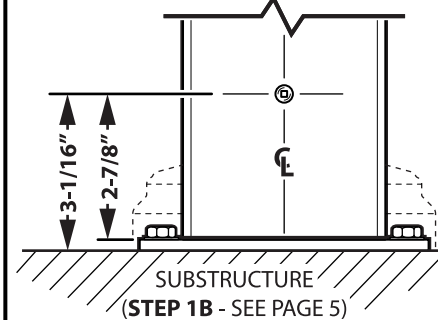

When the bottom post screw has been completely tightened into the post cover and reinforcement, manually loosen the screw about 1/8 of a turn. This will leave the fasteners exposed so that the 'L' brackets can be slid down onto them after they have been installed on the rail sections.

### IMPORTANT

ALWAYS INSTALL POST REINFORCEMENT SO THAT GAP FACES AWAY FROM THE DIRECTION OF LOAD (ie. leaning person)

## POST INSTALLATION & MEASURING

Before installing your new vinyl-clad railing make sure your substructure has been built properly and conforms to local building codes. Install your newel posts using the installation instructions outlined on page 5. After steps on page 5 have been followed refer to page 3 for further instructions.

The newel post reinforcements are to be installed with a **MAXIMUM** length of 8'-0" or 6"- 4" for glass railings, center to center.

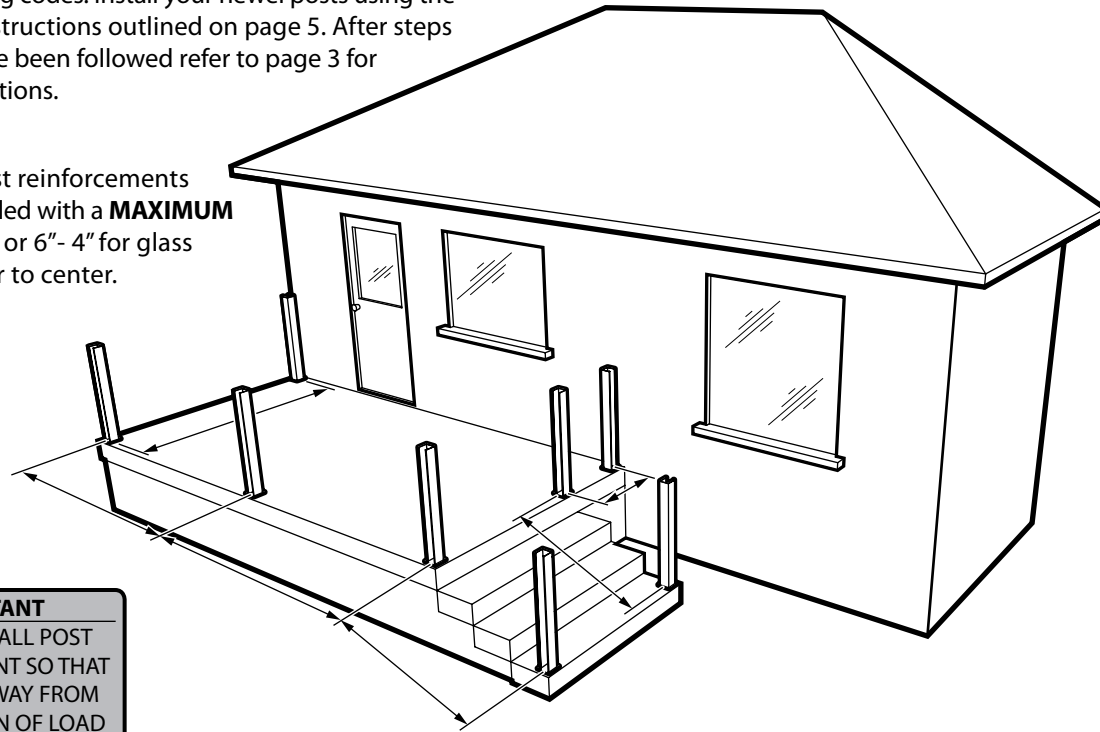

**IMPORTANT**  
ALWAYS INSTALL POST REINFORCEMENT SO THAT GAP FACES AWAY FROM THE DIRECTION OF LOAD (ie. leaning person)

## MEASURING & CUTTING RAILING SECTIONS

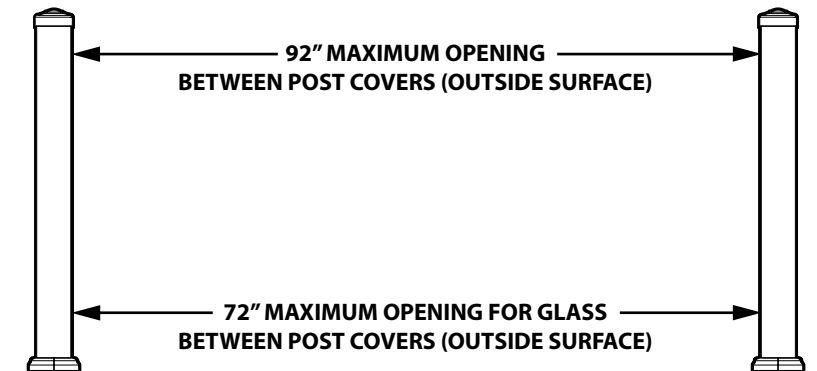

After your newel posts have been installed you must measure the lengths of your required railing sections. Measurements must be taken face to face (As indicated in the illustration) and should be measured in both top and bottom areas as a fail safe. If sections need to be cut they should be cut symmetrically from the center. (ie. If you need to reduce the overall length by 3", cut off 1.5" from each end.)

## PART IDENTIFICATION for RAIL ASSEMBLY

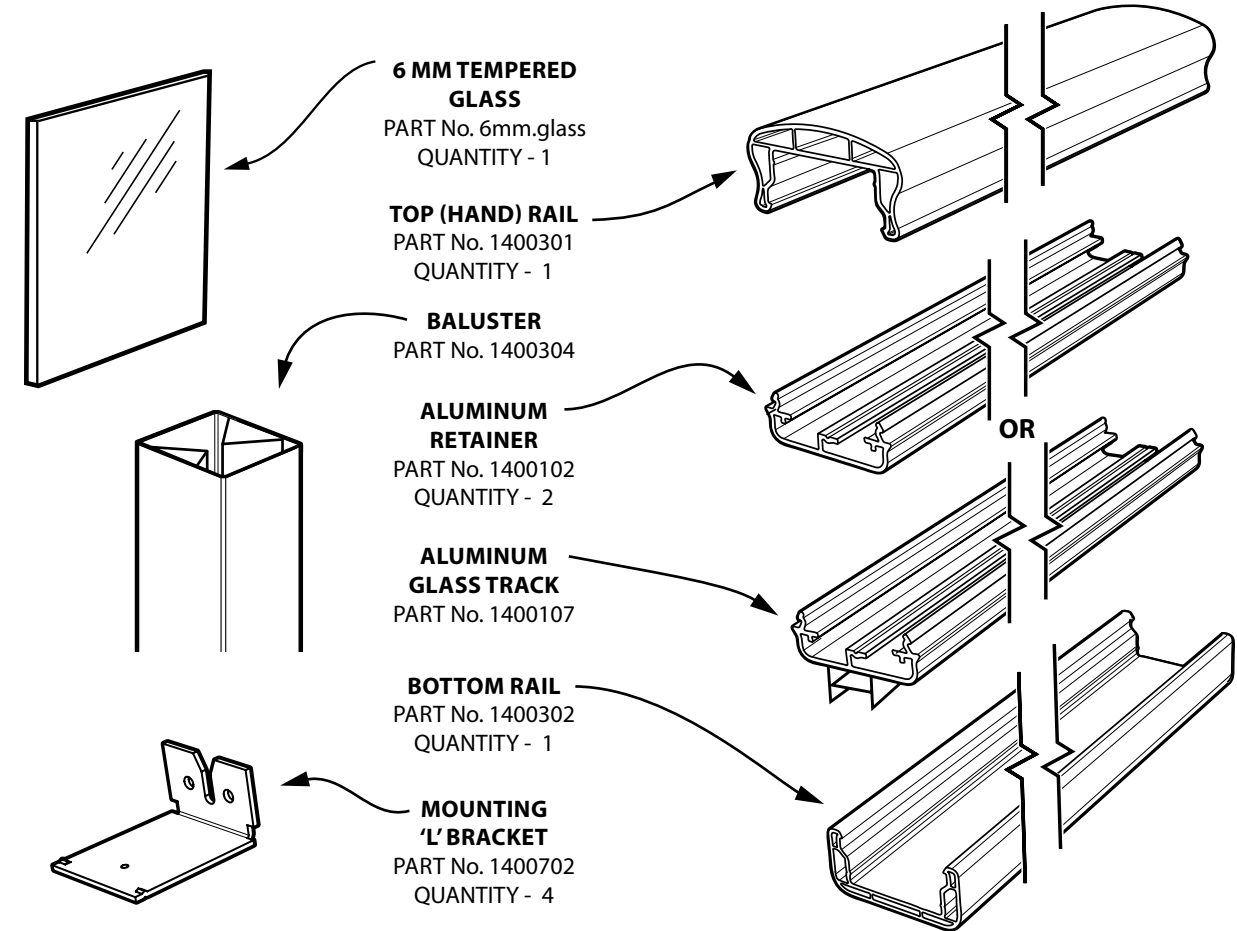

## PART IDENTIFICATION for POST ASSEMBLY

